

Georgian Bars

casement windows with a traditional appearance



Snap-on astragal-bar system offering an effective, stylish and trouble free solution to anyone wishing to achieve an **authentic looking Georgian style double glazed window**

 **synseal**[®]

Tel: 01623 443200 www.synseal.co

Georgian Bars

casement windows with a traditional appearance



Casement windows with a traditional appearance

Synseal's snap-on astragal-bar system offers an effective, stylish and trouble free solution to anyone wishing to achieve an authentic looking Georgian style double glazed window.

The bars are easy to install and are available in a range of colours.

- Reduce production time
- Fast, efficient installation on site if required
- An easy up-sell to consumers, and a good way to get ahead in the new build market
- Dedicated cruciform mouldings enable you to square cut the bars and simply snap into place.



Versatility low level bar components

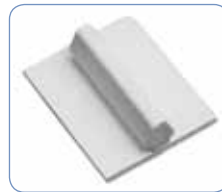

Bridging Intermediate Piece



Featured Bar



Cruciform Clip



Cruciform Cover

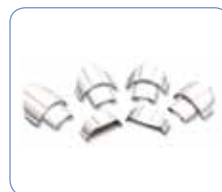

Featured Bar End Cap (Profile related)

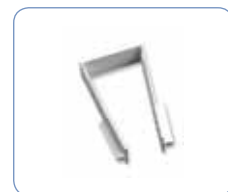

VS Bar Clip



Georgian Bar fixing instructions

Bars can be fitted internally, externally or both, and can be installed on site using U-shaped bar clips that are placed over all four edges of the sealed unit before it is installed in the usual way.

Bars are square cut to fit the shorter span of the window, with allowance for insertion into end caps. Cruciform clips are fitted to the bars and spaced to align with intermediate spacer bars and the U-shaped clips on the shorter sides of the window. The bars are then snapped into position on the U-shaped clips. Short sections of bar are then simply cut, inserted into end caps and cruciform cover mouldings, and clipped into position between the continuous bars to provide the individual small pane effect. This method of installation enables the system to be fitted retrospectively to existing windows and allows it to be re-used in the event of breakage or failure of a sealed unit. All bars are held firmly in position by the clips.

Detail: Tape application

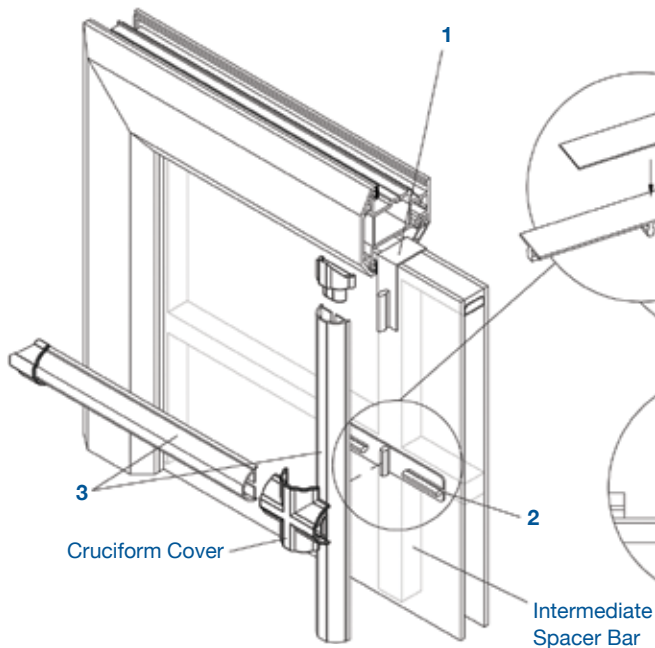

Detail: Bar length over clip

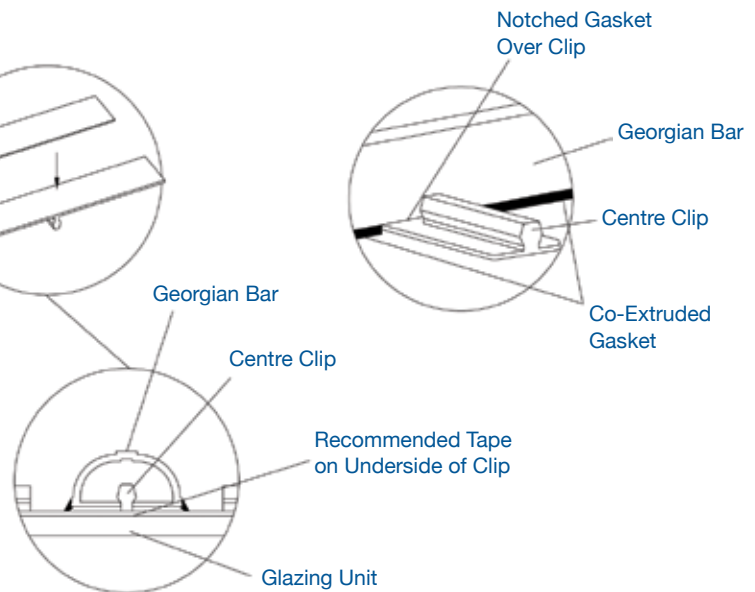

Step 1

Place edge clips in the required positions around the sealed glazing unit.

Step 2

Glaze window as per manufacturing and glazing instructions in the applicable technical manual. Ensure that clips have retained their position prior to final beading. Adjustment of clip position following final beading should be minimal.

Step 3

Accurately align the centre clip to the edge clips. Once located the clip can be fixed using a length, approximately 40mm, of double sided tape (see notes 1 and 2). This should be placed in the centre of the underside of the clip, as shown above. Prior to tape application ensure all surfaces are clean, dry and free of grease.

Step 4

Square cut the full length bar with allowance for end caps. This should always be the shortest span for increased rigidity. To avoid arching of full length bars, notch out the extruded gaskets where the bar crosses across the centre clip. This should allow the bar to sit flat against the glass. See detail: Bar length over clip detail and Step 3.

Step 5

Cut the remaining bars prior to fitting and ensure the lengths are cut accurately, allowing for end caps and cruciform cover mouldings. Insert bars into mouldings before clipping into place to align with intermediate spacer bars. For spans greater than 300mm a single bridging clip and a patch of tape should be used at midpoints to increase rigidity.

Repeat steps 1-5 for opposite side.

Notes:

1. Tape: Recommendation - In controlled factory glazing or for on site application above 0°C, it is recommended that GBT40-500 or GBT16-500 at 1.1mm be used. The characteristics of the tape will allow for strong bonding in such conditions. The tape may produce a gap approximately 0.5mm between bar and glazing unit at the centre clip, however this will not affect performance. 2. Adhesive tapes should be applied as per manufacture instructions. 3. Thermal expansion allowance in cutting size should be used: White PVCU allow 1.6mm/m, Coloured/Foiled allow 2.4mm/m. Bar lengths should be processed at minimum 17°C up to standard workshop temperature (assumed 21°C). 4. Storage of system must comply with Technical Delivery Specification from your systems supplier 5. Care should be taken during any further transportation to ensure bar lengths are suitable for application.

Code	Description	Pack Size
Fixing Tape		
GBT40-500	40mm x 5m VHB Grey Cruciform Tape	5
GBT16-500	16mm x 5m VHB Grey Bridging Piece Tape	5
Featured Bar		
GBF-300-LEG	3m Featured L/Level Bar Legend 70 White - Black Flipper	60m
GBF-300-SYN	3m Featured L/Level Bar SynerJy/Shield White - Black Flipper	60m
GBF-300-OAK	3m Featured L/Level Bar Golden Oak Foil - Acorn Flipper	30m
GBF-300-CHW	3m Featured L/Level Bar Cherrywood Foil - Black Flipper	30m
GBF-300-W	3m Featured L/Level Bar Mahogany Foil - Black Flipper	30m
Geofast Clips		
GBM-DSC	28mm Double Sided Clip - White	100
GBM-DSCB	28mm Double Sided Clip - Brown	100
GBM-DSCC	28mm Double Sided Clip - Caramel	100
GBM-CC	Cruciform Clip - White	50
GBM-CC-B	Cruciform Clip - Brown	50
GBM-CC-C	Cruciform Clip - Caramel	50
GBM-IBP	Intermediate Bridging Piece - White	100
GBM-IBP-B	Intermediate Bridging Piece - Brown	100
GBM-IBP-C	Intermediate Bridging Piece - Caramel	100
Cruciform Covers		
GBM-CJC	Cruciform Joint Cover - White	50
GBM-CJC-OAK	Cruciform Joint Cover - Golden Oak	25
GBM-CJC-CHW	Cruciform Joint Cover - Cherrywood	25
GBM-CJC-W	Cruciform Joint Cover - Mahogany	25

Code	Description	Pack Size
End Clips		
Legend 70		
GBM-5CF	Chamfered Frame End Cap - White	100
GBM-5CF-OAK	Chamfered Frame End Cap - Golden Oak	50
GBM-5CF-CHW	Chamfered Frame End Cap - Cherrywood	50
GBM-5CF-W	Chamfered Frame End Cap - Mahogany	50
GBM-5OJB	Ovolo Bead End Cap - White	100
GBM-5OJB-OAK	Ovolo Bead End Cap - Golden Oak	50
GBM-5OJB-CHW	Ovolo Bead End Cap - Cherrywood	50
GBM-5OJB-W	Ovolo Bead End Cap - Mahogany	50
Shield		
GBM-6CF	Chamfered Frame End Cap - White	100
GBM-6CF-OAK	Chamfered Frame End Cap - Golden Oak	50
GBM-6CF-CHW	Chamfered Frame End Cap - Cherrywood	50
GBM-6CF-W	Chamfered Frame End Cap - Mahogany	50
GBM-6OJB	Ovolo Bead End Cap - White	100
GBM-6OJB-OAK	Ovolo Bead End Cap - Golden Oak	50
GBM-6OJB-CHW	Ovolo Bead End Cap - Cherrywood	50
GBM-6OJB-W	Ovolo Bead End Cap - Mahogany	50
SynerJy		
GBM-4F	Frame End Cap - White	100
GBM-4F-OAK	Frame End Cap - Golden Oak	50
GBM-4F-CHW	Frame End Cap - Cherrywood	50
GBM-4F-W	Frame End Cap - Mahogany	50
GBM-4SJB	Scribe-in J Bead End Cap - White	100
GBM-4SJB-OAK	Scribe-in J Bead End Cap - Golden Oak	50
GBM-4SJB-CHW	Scribe-in J Bead End Cap - Cherrywood	50
GBM-4SJB-W	Scribe-in J Bead End Cap - Mahogany	50

Colour options:

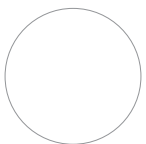

**Shield/SynerJy
White**

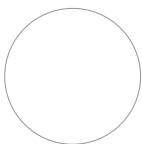

**Standard
Legend 70 White**



Golden Oak

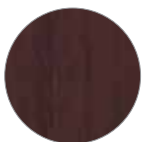

Cherrywood



Mahogany

The above colours are designed as a guide. Before making your final decision, please ensure you have seen a swatch.

 **synseal**[®]
www.synseal.co

Synseal Extrusions Ltd
Common Road, Huthwaite, Nottinghamshire, NG17 6AD

Tel: +44 (0)1623 443200 | **Fax:** +44 (0)1623 550243